

REV.	DESCRIPTION	BY	DATE
ORIG.	DRAWING ISSUE	SANDY CHEN	11.03.2010
A	ADD DIMENSIONS	SANDY CHEN	11.11.2010

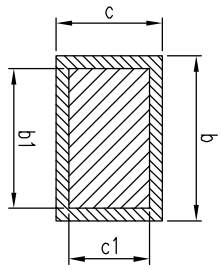

SYMBOL	DIMENSION IN MM			DIMENSION IN INCH		
	MIN.	NOM.	MAX.	MIN.	NOM.	MAX.
A		1.20				0.047
A1	0.05	0.10	0.15	0.002	0.004	0.006
A2	0.80	1.00	1.05	0.031	0.039	0.041
b	0.19		0.30	0.0075		0.012
b1	0.19	0.22	0.25	0.0075	0.009	0.010
c	0.09		0.20	0.0035		0.008
c1	0.09	0.127	0.16	0.0035	0.005	0.008
e	0.65 BASIC			0.026 BASIC		
D	2.90	3.00	3.10	0.114	0.118	0.122
E	6.20	6.40	6.60	0.244	0.252	0.260
E1	4.30	4.40	4.50	0.169	0.173	0.177
L	0.45	0.60	0.75	0.018	0.024	0.030
L1	1.0 REF			0.0394 REF		
R1	0.09			0.004		
R	0.09			0.004		
S	0.20			0.008		
Ø1	Ø		8°	Ø		8°
Ø2	12° REF			12° REF		
Ø3	12° REF			12° REF		
JEDEC	MO-153 (AA)					

*NOTES : DIMENSION "Ø" DOES NOT INCLUDE MOLD FLASH, PROTRUSIONS OR GATE BURRS.
 MOLD FLASH, PROTRUSIONS OR GATE BURRS SHALL NOT EXCEED 0.15MM PER SIDE.
 DIMENSION "E" DOES NOT INCLUDE INTERLEAD FLASH OR PROTRUSION.
 INTERLEAD FLASH OR PROTRUSION SHALL NOT EXCEED 0.25MM PER SIDE.

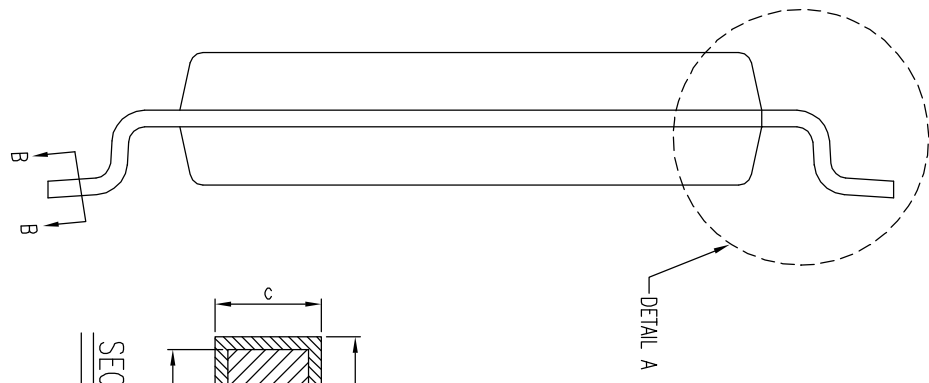
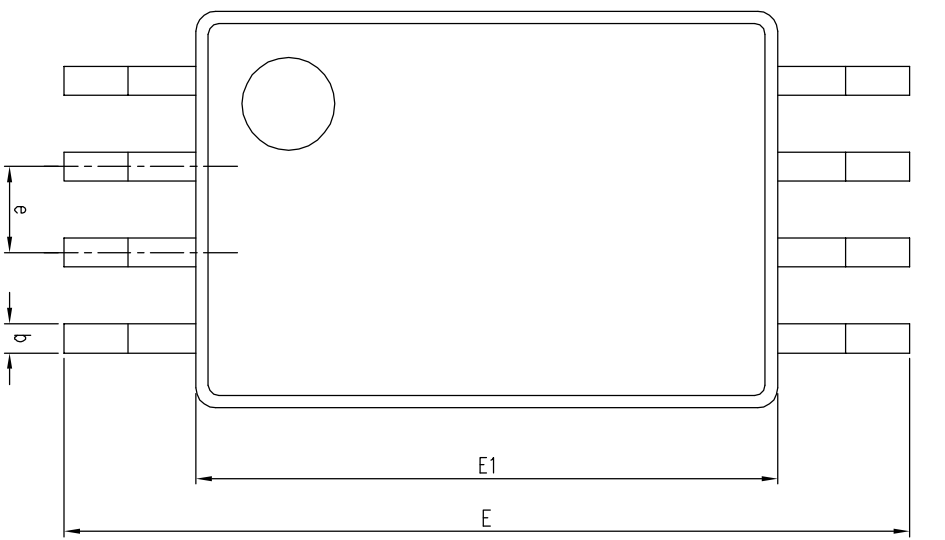
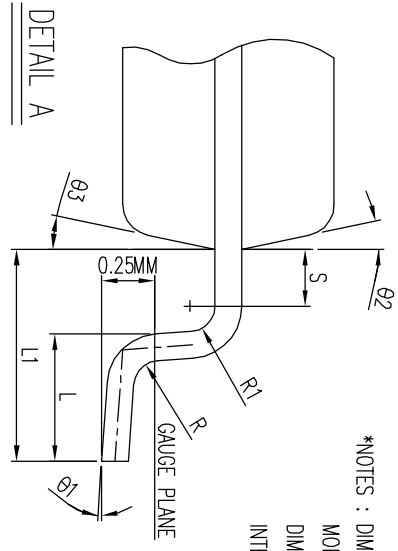
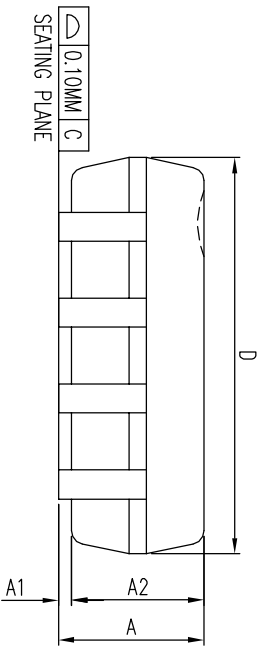

TITLE TSSOP 8L PACKAGE OUTLINE BODY WIDTH : 4.4mm		ANGULAR ± ROUGH- MESS SCALE QTY
DESIGNED	SANDY CHEN 11.03.2010	UNIT
CHECKED	SANDY CHEN 11.11.2010	FILE NAME : PRF008P1
APPROVED	SANDY CHEN 11.11.2010	DWG. NO. : CW-PR-001B
		A3